



德國威樂熱水循環泵浦系列

STAR / TOP Series



TOP-S IN-LINE 循環泵

TOP-S-60HZ

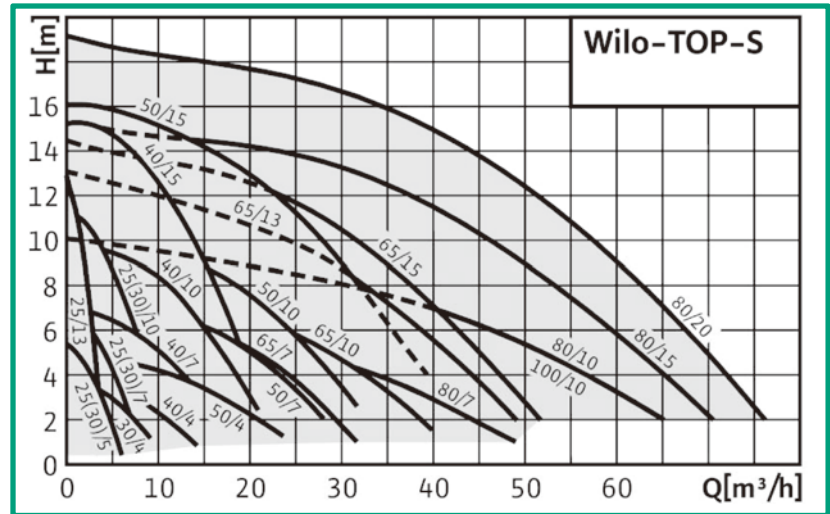

Wilo-TOP-S 系列

- IN-LINE 循環泵
- 運轉低噪音

應用範圍

- 熱水循環系統
- 熱泵、太陽能系統
- 工業用循環水系統
- 鍋爐回水系統

技術資料

流體

熱水(VDI 2035)

特性

速度範圍 1200-2900rpm

3段手動變速

流體溫度 -20°C ~ +130°C

二小時內短時間運轉 +140°C

最大工作壓力： 6/10 bar

環境溫度 max. +40°C

電源

送電方式 1~220V 50/60HZ

3~380-460V 50/60HZ

選配 3~220V 50/60HZ

馬達

保護等級 IP 44

絕緣等級 H

設計標準 EN 61000-6-2

EN 61000-6-3

材質

泵浦機身 鑄鐵

葉輪 GF-PP

軸心 不銹鋼

軸承 石墨

供應範圍

- 泵浦完整包裝及操作保養手冊

配件

- 選配泵浦保溫外殼
- 選配其他配件

安裝方式

- 泵浦軸心需在水平方向
- 接線盒可選擇3、6、9、12點鐘方向

泵浦配備

- 三段手動變速調整
- 非過載型單相馬達
- 接線盒左右均可使用

馬達

- 電壓可1~220-230V 50/60Hz 共用
- 選配1~110V 60Hz

TOP-S 性能	最大耐壓等級	環境溫度40°C時，泵浦輸送水溫所需的最小正壓[m]			
		50°C	95°C	110°C	130°C
25/5-25/7	10 bar	0.5	5	11	24
25/10	10/16 bar				
25/13	10 bar	0.5	5	11	-
30/4-30/7	10 bar	0.5	5	11	24
30/10	10/16 bar				
40/4-40/10	6/10, 16 bar	3.0	10	16	29
40/15	6/10, 16 bar				
50/4-50/15	6/10, 16 bar				
65/7-65/15	6/10, 16 bar				
80/7-80/10	6, 10/16 bar	9.0	18	23	36
80/15-80/20	6, 10/16 bar				
100/10	6, 10/16 bar	3.0	10	16	29



TOP-S IN-LINE 循環泵

TOP-S-60HZ

TOP-S 25/5, 30/5 EM (1~220V)

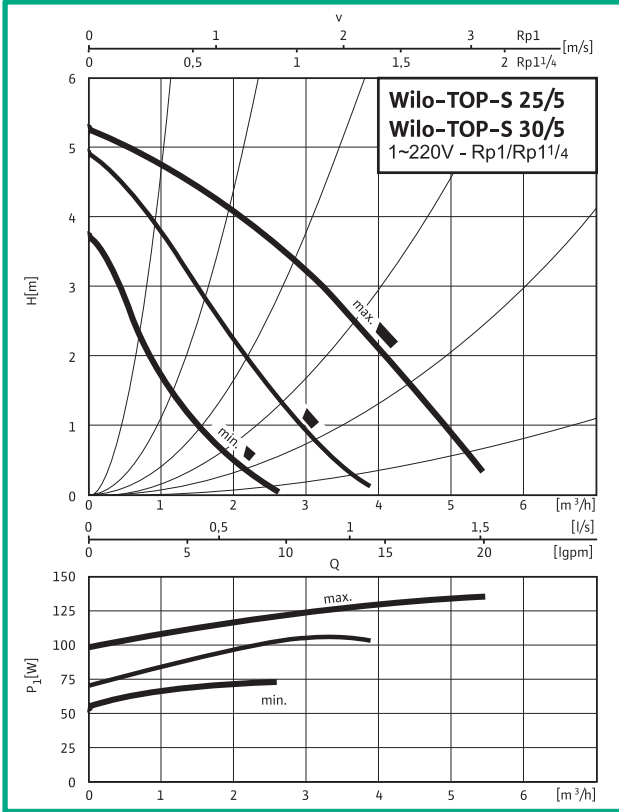

TOP-S 25/5, 30/5 DM (3~380V)

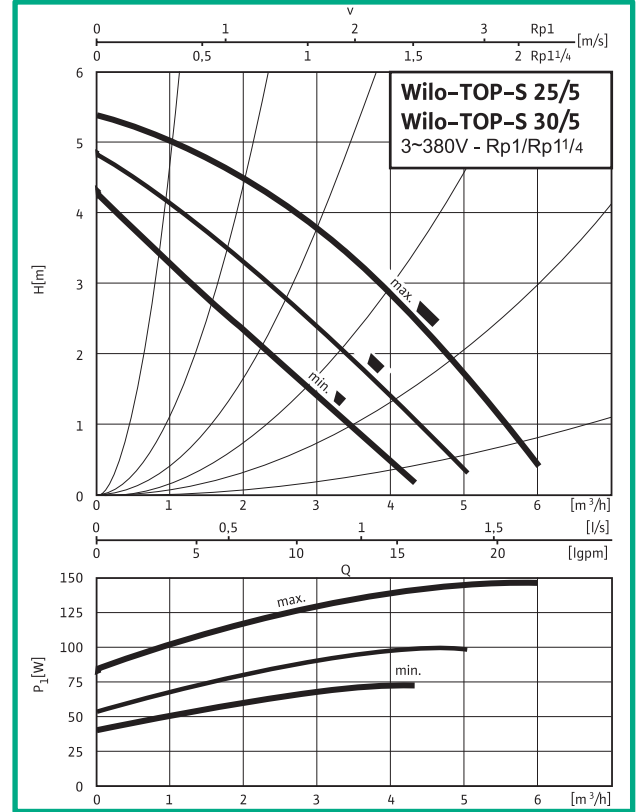

TOP-S 25/7, 30/7 EM (1~220V)

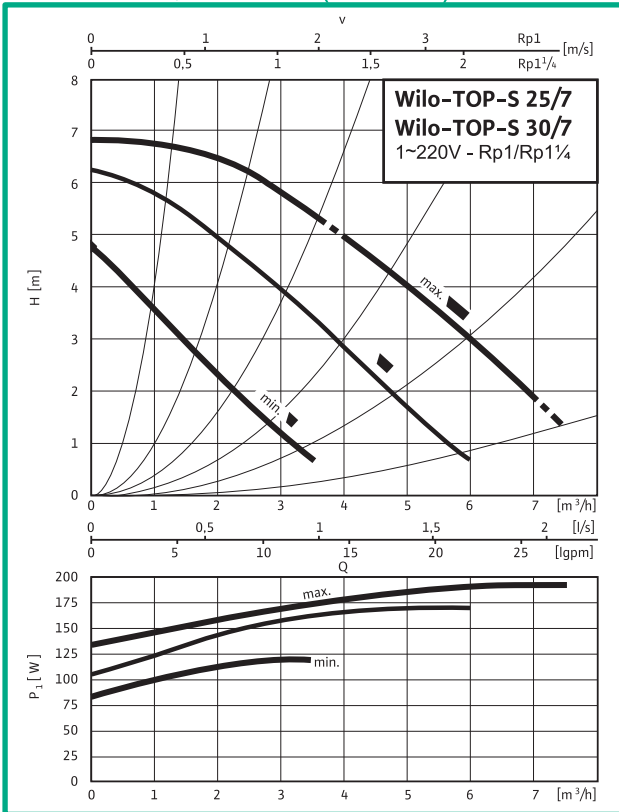

TOP-S 25/7, 30/7 DM (3~380V)

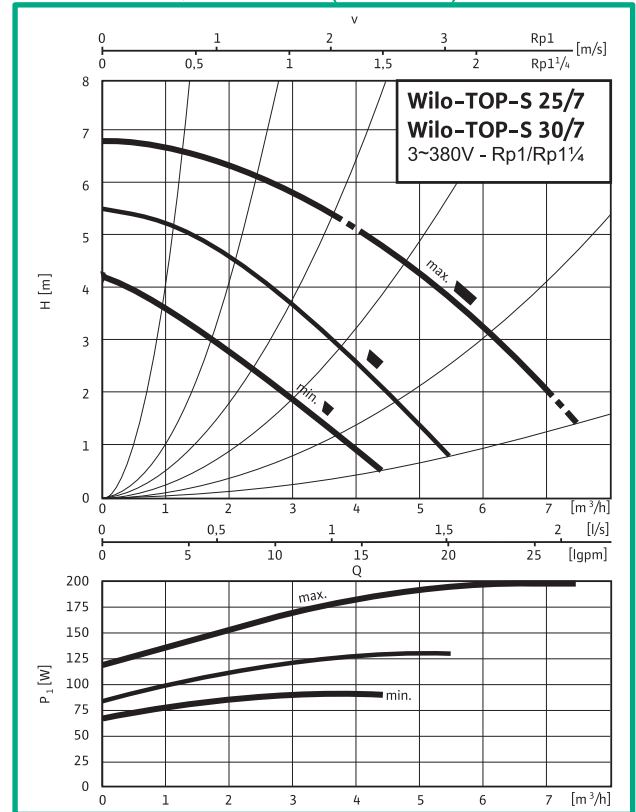



TOP-S IN-LINE 循環泵

TOP-S-60HZ

TOP-S 25/10, 30/10 EM (1~220V)

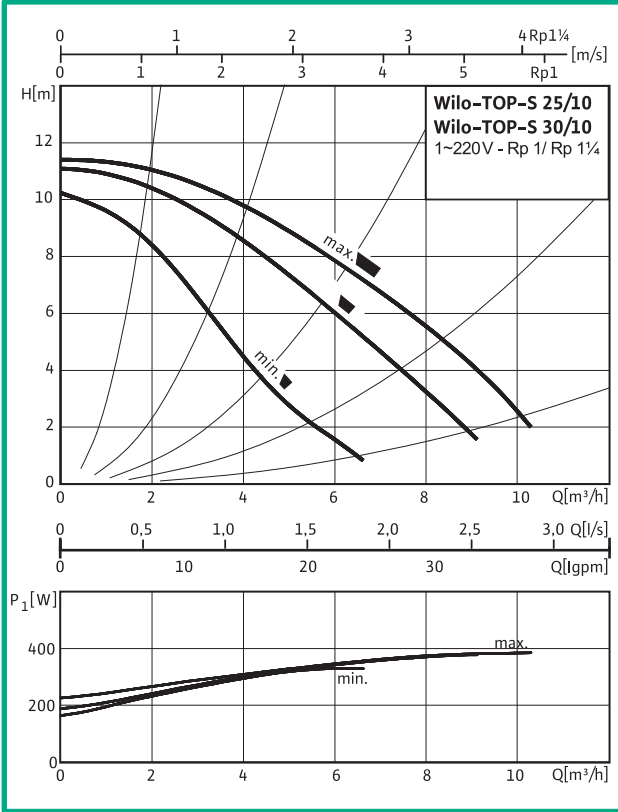

TOP-S 25/10, 30/10 DM (3~380V)

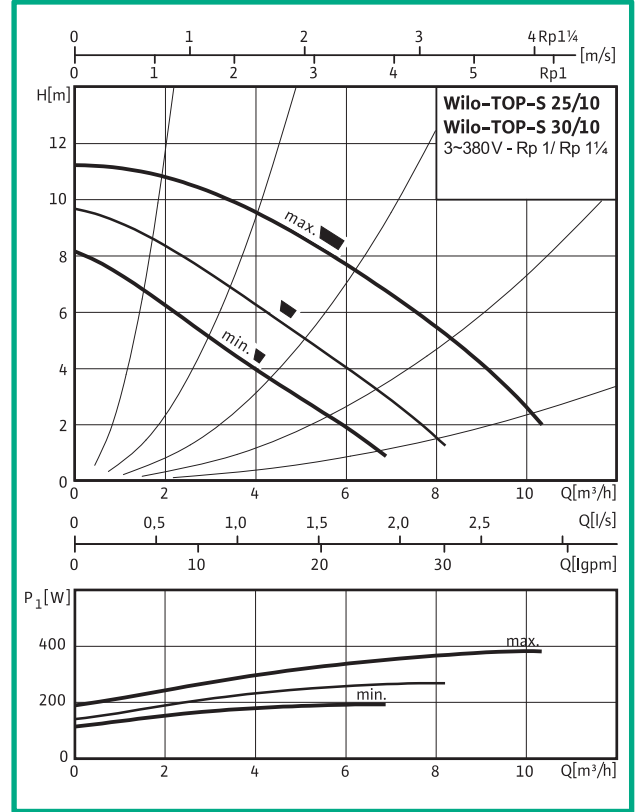

TOP-S 25/13 EM (1~220V)

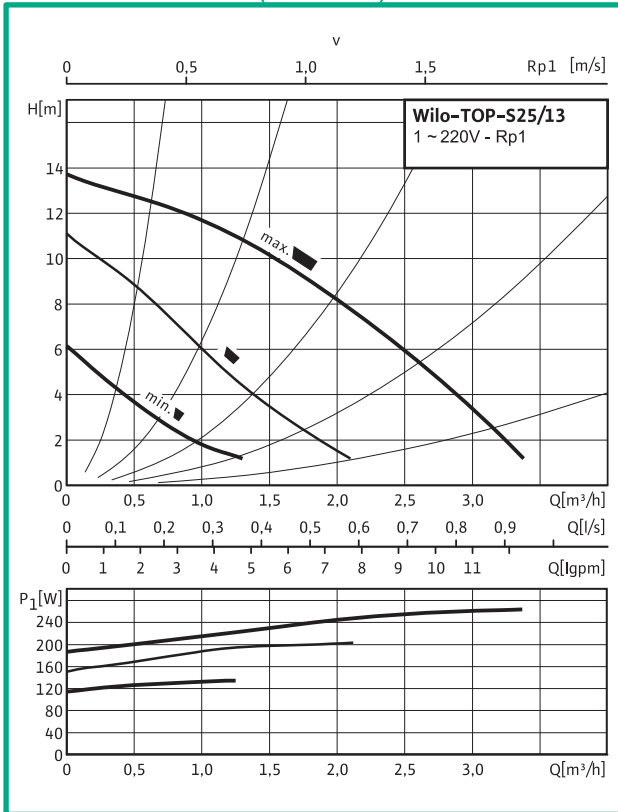

TOP-S 25/13 DM (3~380V)

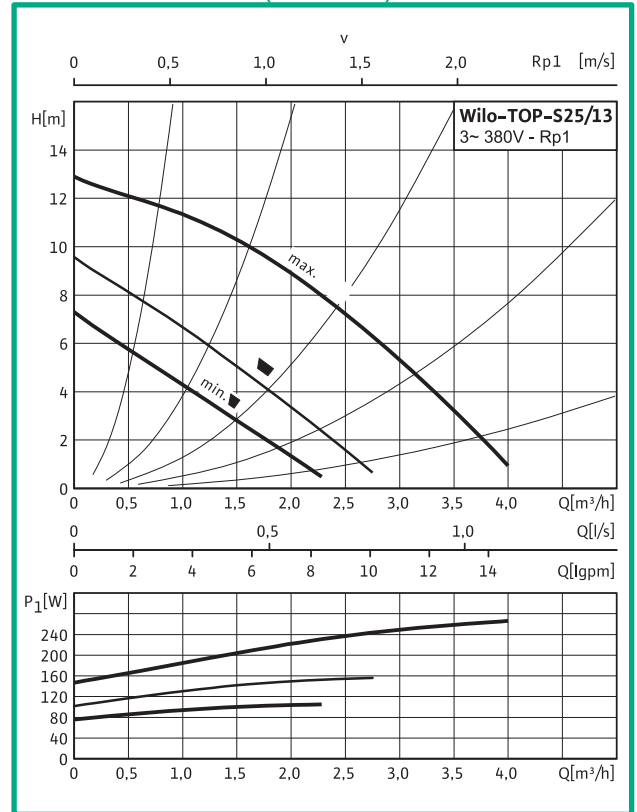



TOP-S IN-LINE 循環泵

TOP-S-60HZ

TOP-S 30/4 EM (1~220V)

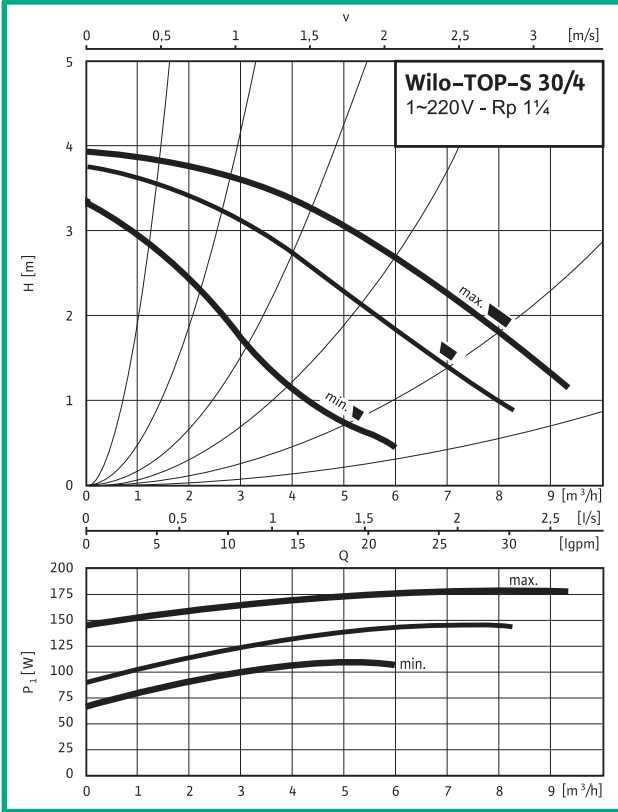

TOP-S 30/4 DM (3~380V)

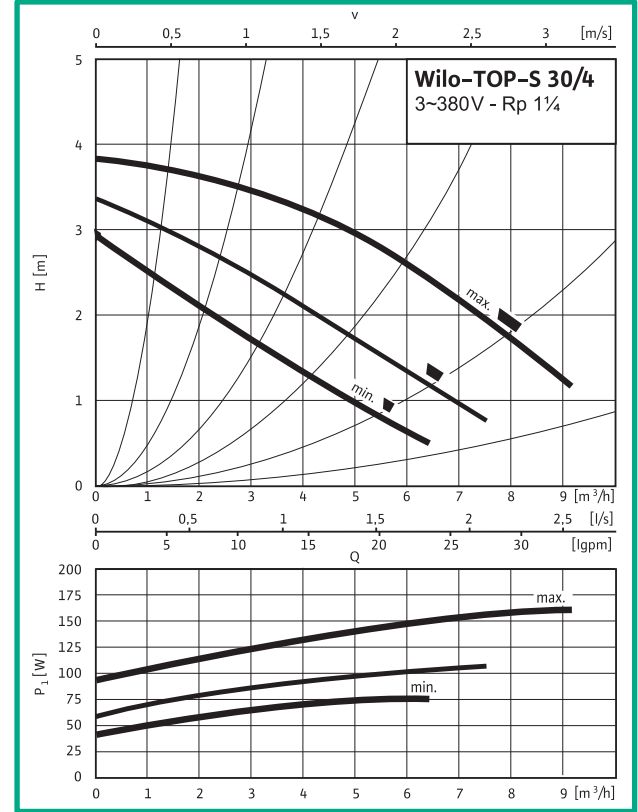

TOP-S 40/4 EM (1~220V)

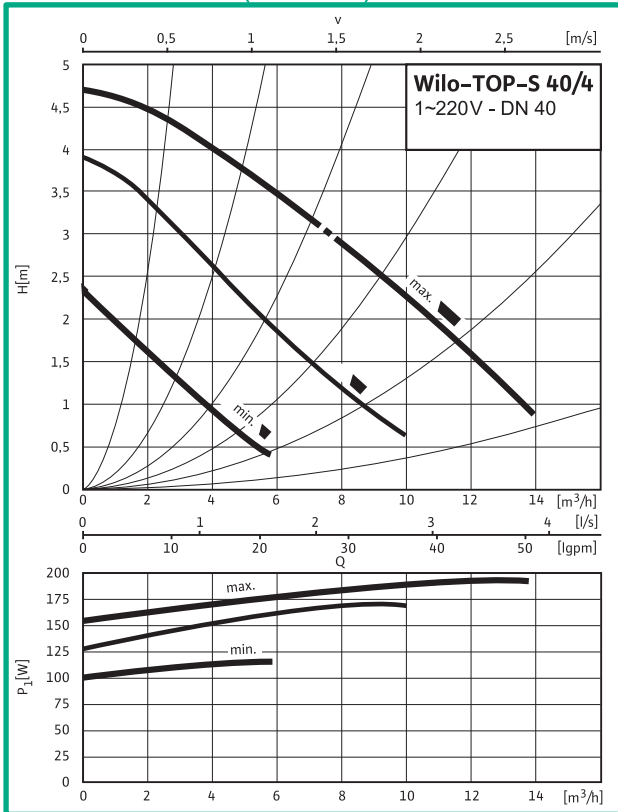

TOP-S 40/4 DM (3~380V)

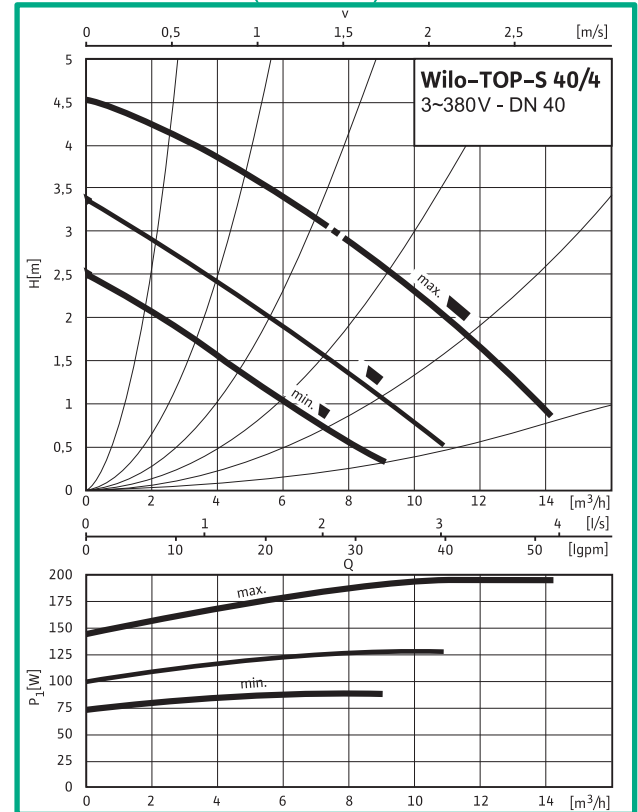



TOP-S IN-LINE 循環泵

TOP-S-60HZ

TOP-S 40/7 EM (1~220V)

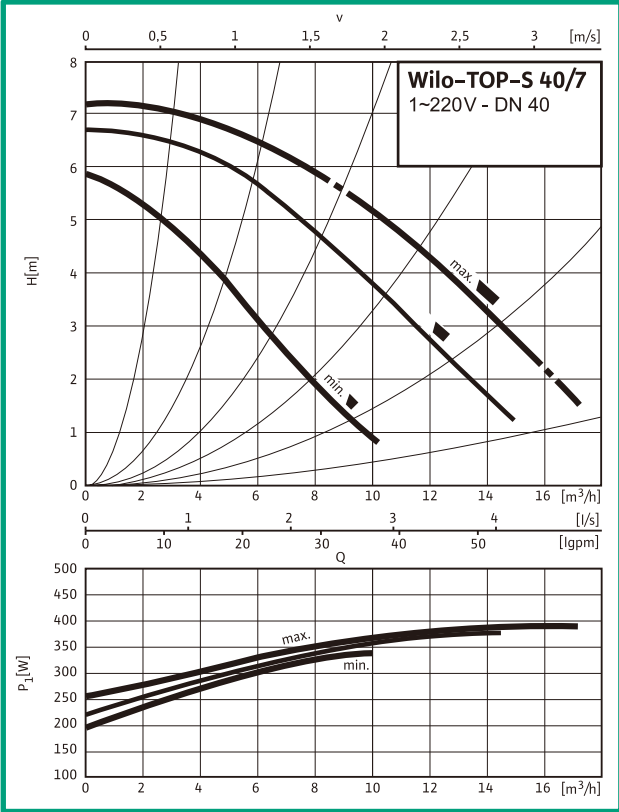

TOP-S 40/7 DM (3~380V)

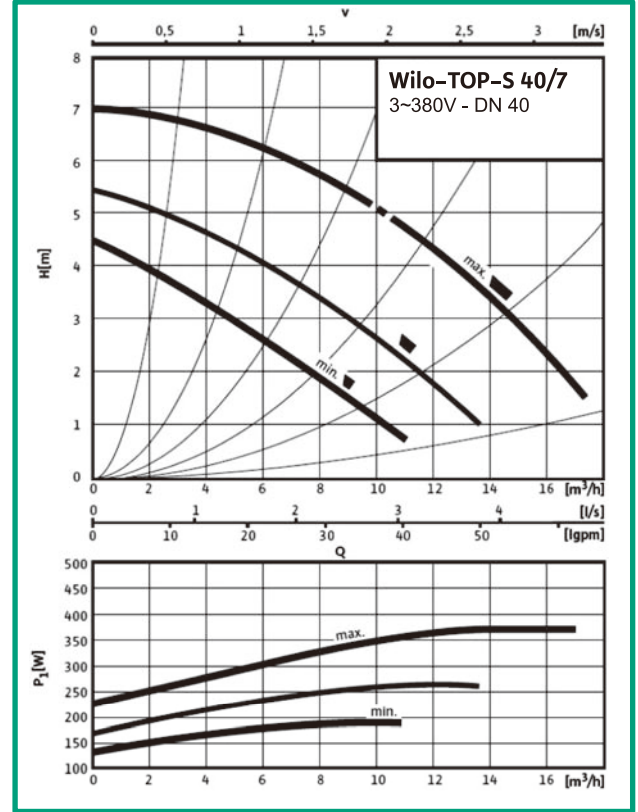

TOP-S 40/10 EM (1~220V)

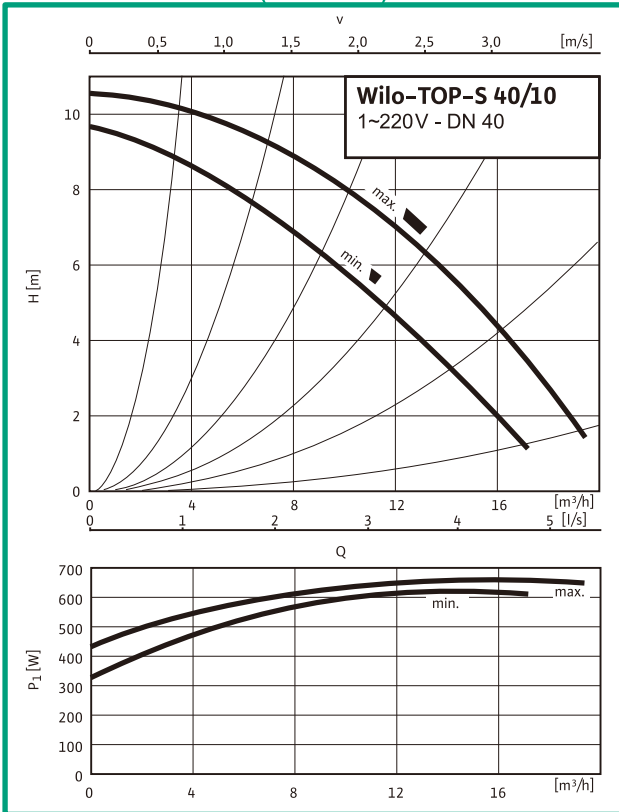

TOP-S 40/10 DM (3~380V)

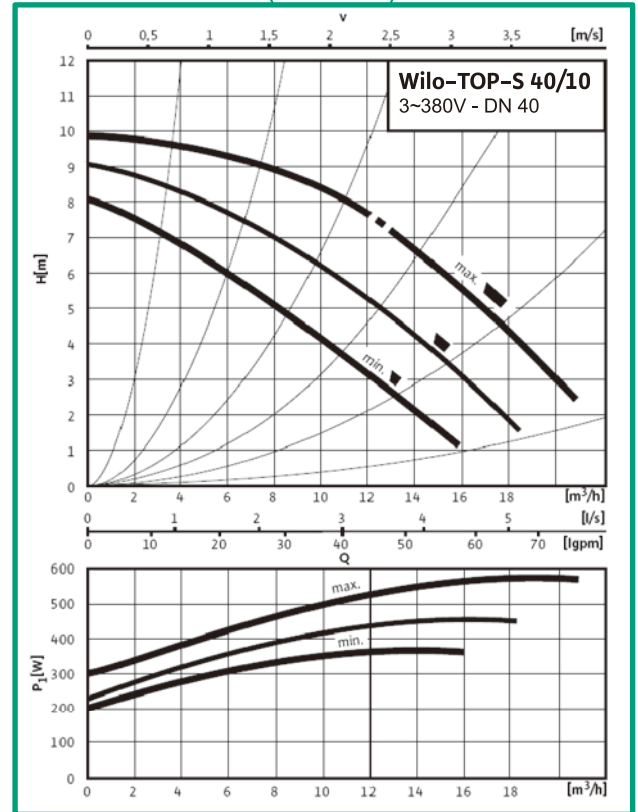



TOP-S IN-LINE 循環泵

TOP-S-60HZ

TOP-S 40/15 EM (1~220V)

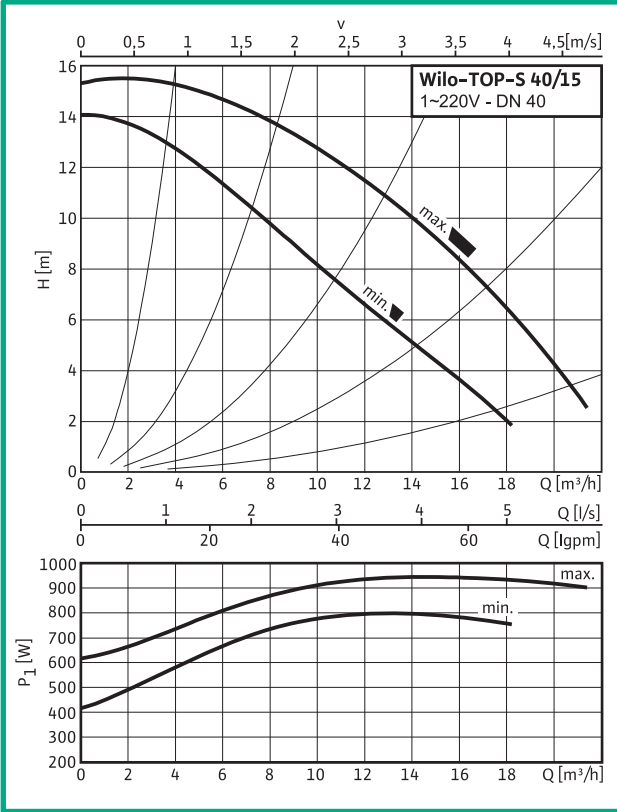

TOP-S 40/15 DM (3~380V)

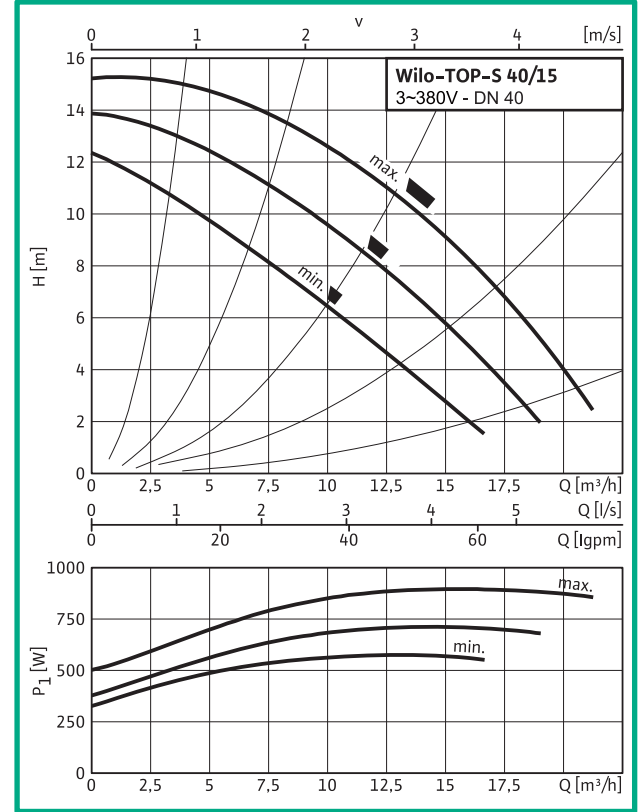

TOP-S 50/4 EM (1~220V)

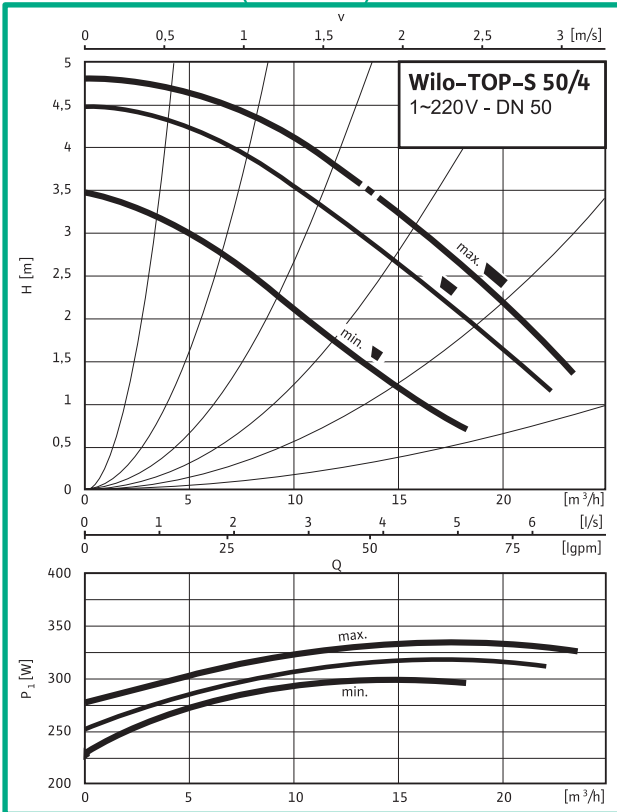

TOP-S 50/4 DM (3~380V)

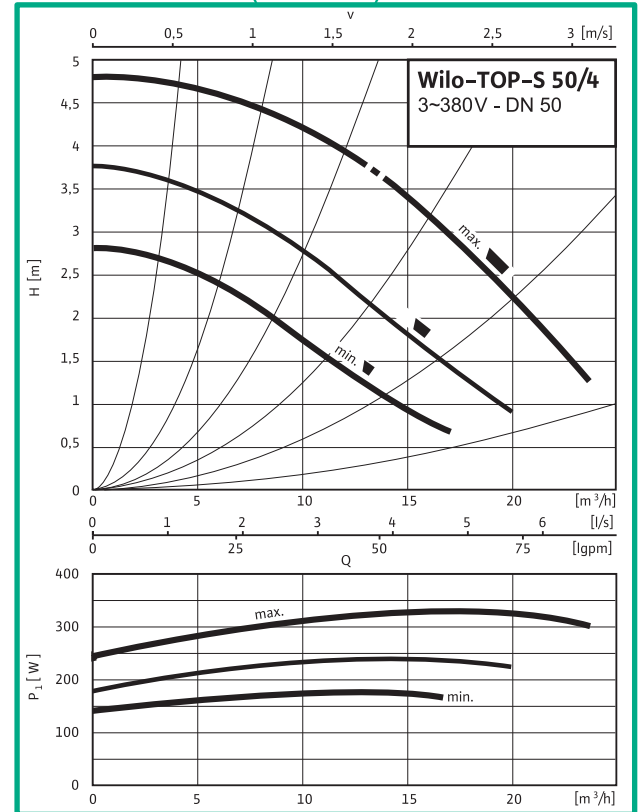



TOP-S IN-LINE 循環泵

TOP-S-60HZ

TOP-S 50/7 EM (1~220V)

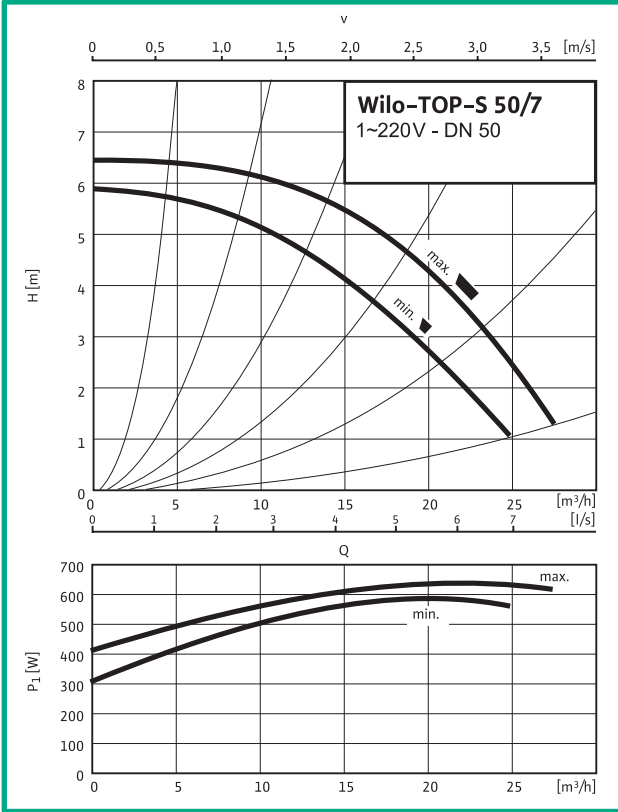

TOP-S 50/7 DM (3~380V)

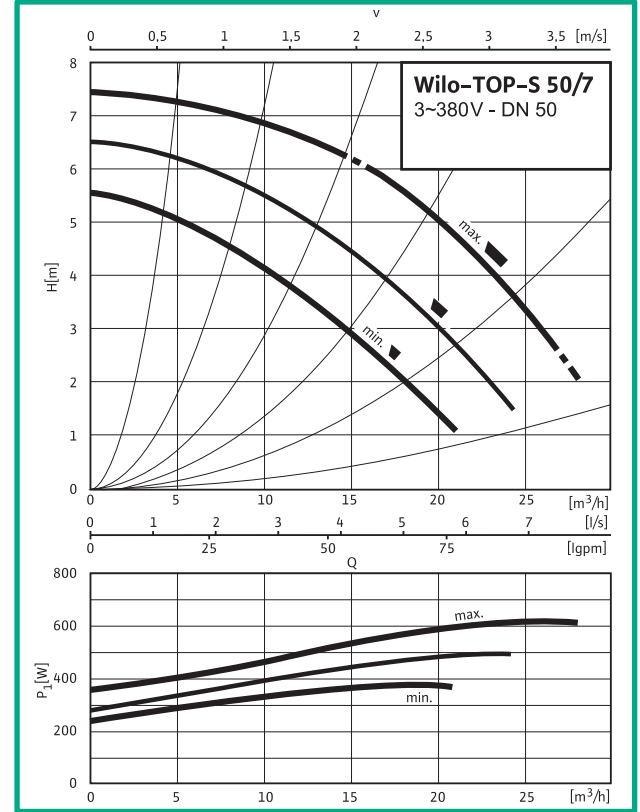

TOP-S 50/10 EM (1~220V)

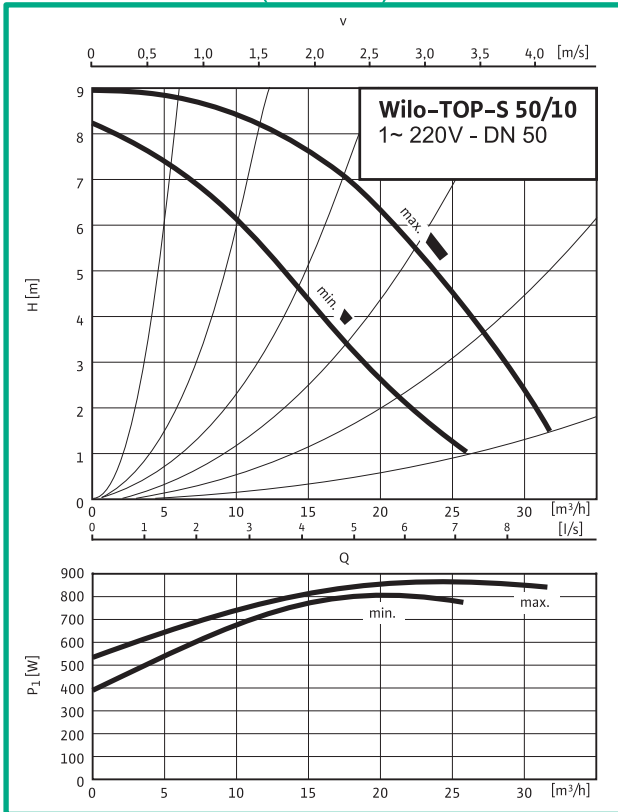

TOP-S 50/10 DM (3~380V)

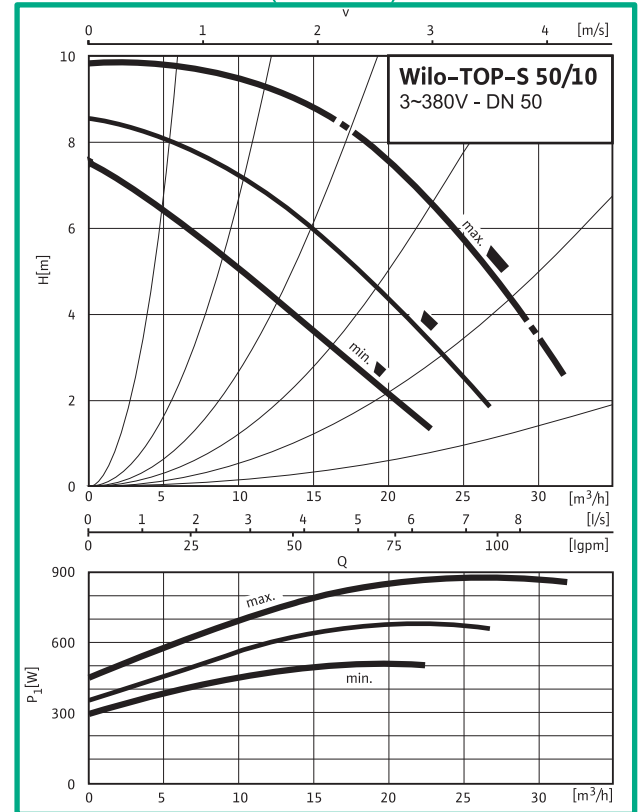



TOP-S IN-LINE 循環泵

TOP-S-60HZ

TOP-S 50/15 EM (1~220V)

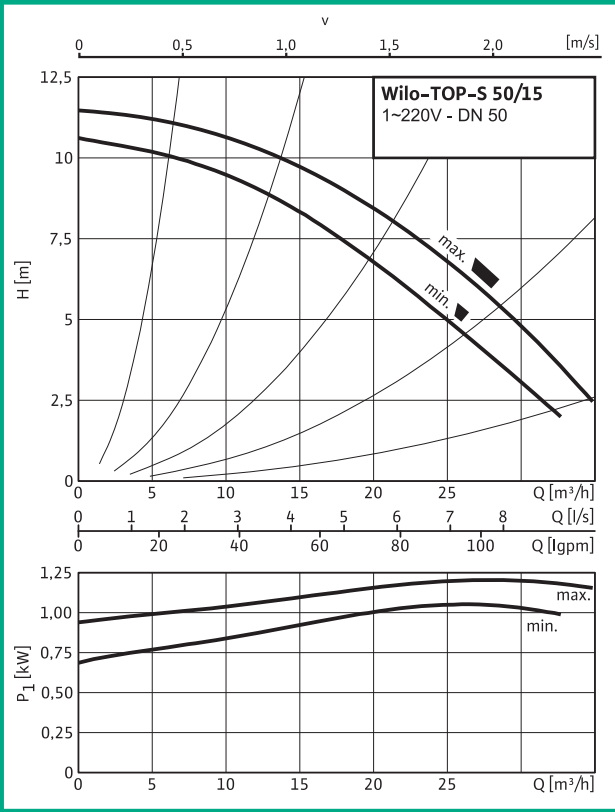

TOP-S 50/15 DM (3~380V)

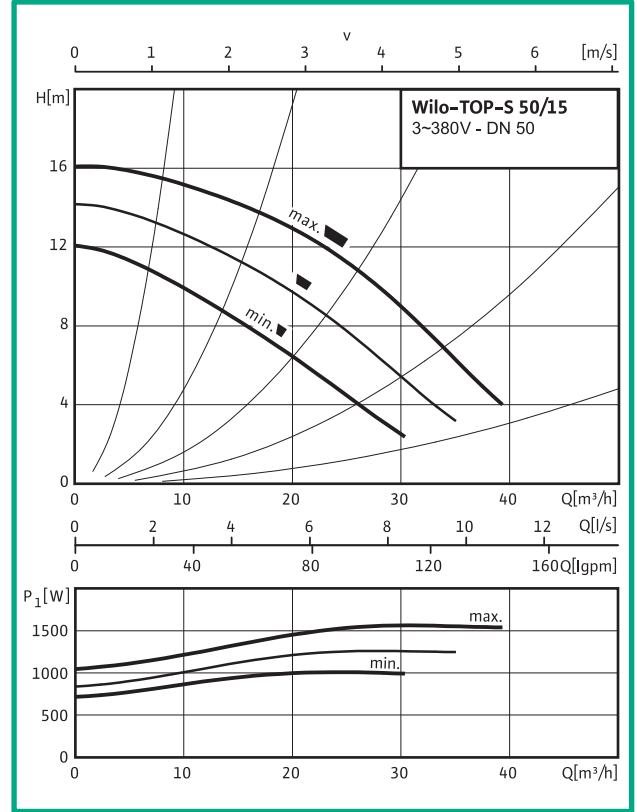

TOP-S 65/7 EM (1~220V)

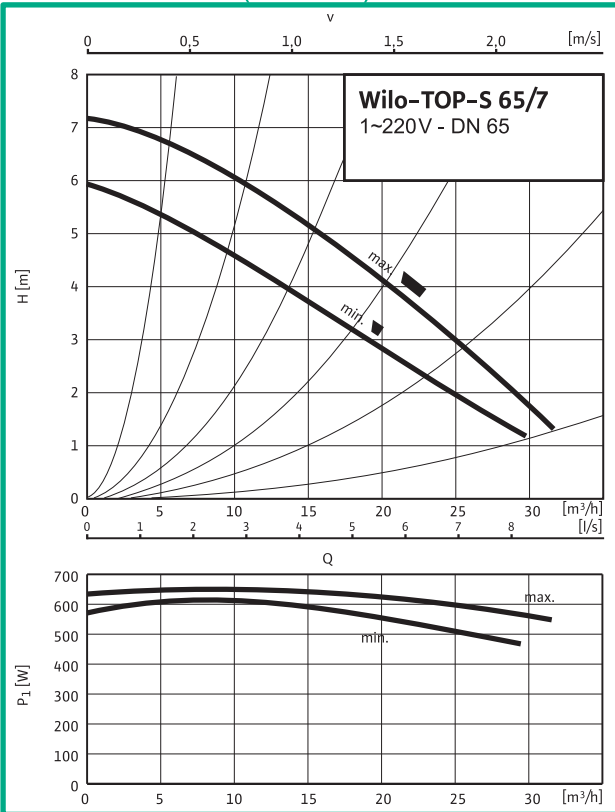

TOP-S 65/7 DM (3~380V)

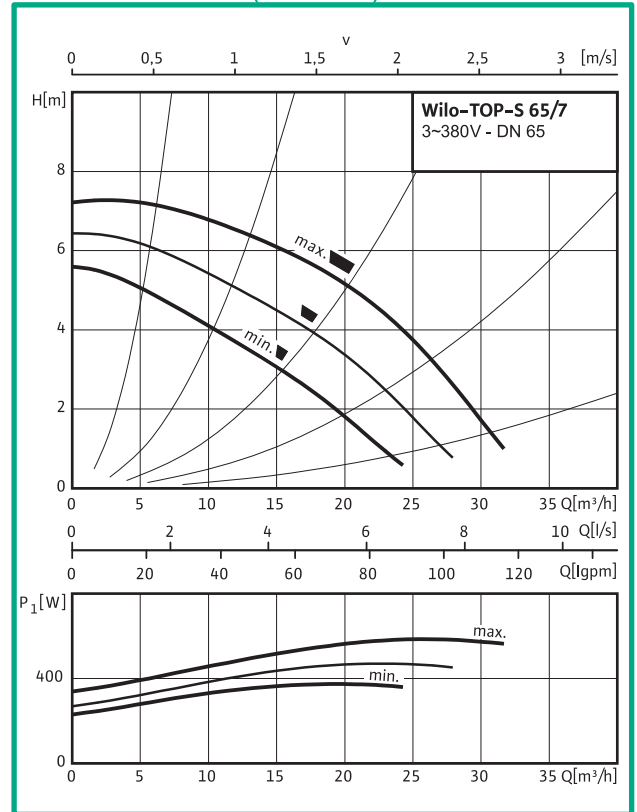



TOP-S IN-LINE 循環泵

TOP-S-60HZ

TOP-S 65/10 EM (1~220V)

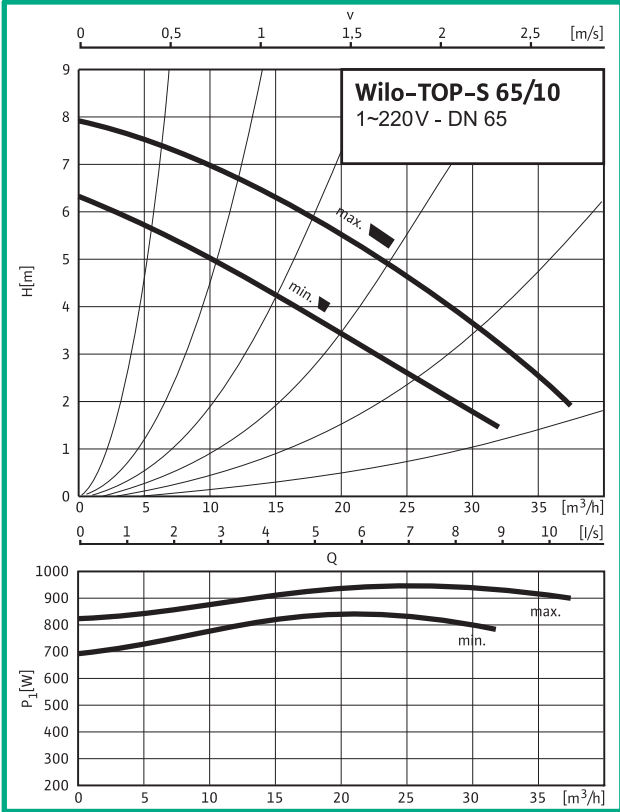

TOP-S 65/10 DM (3~380V)

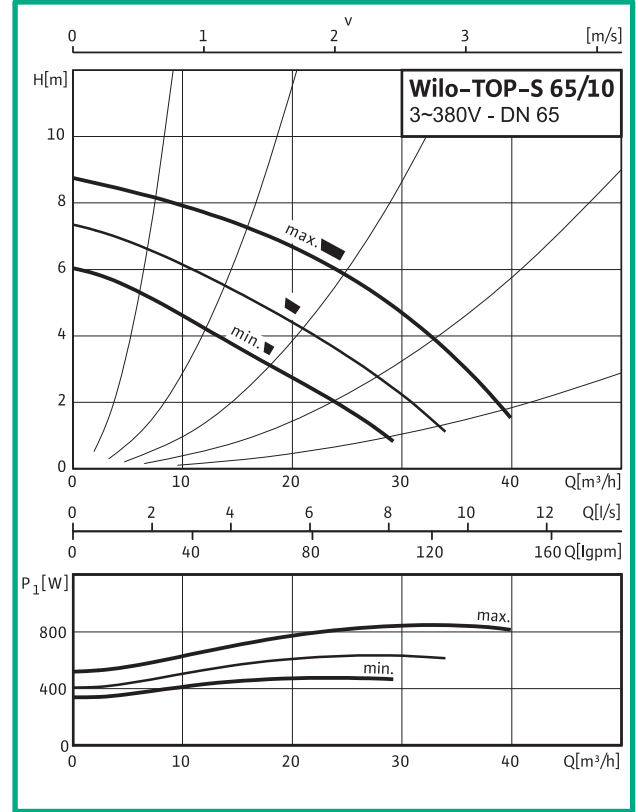

TOP-S 65/13 EM (1~220V)

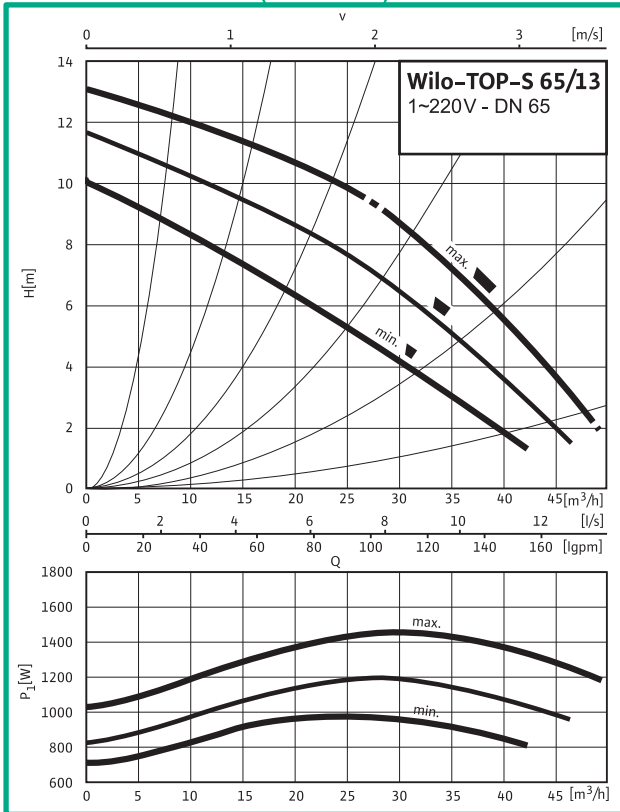

TOP-S 65/15 DM (3~380V)

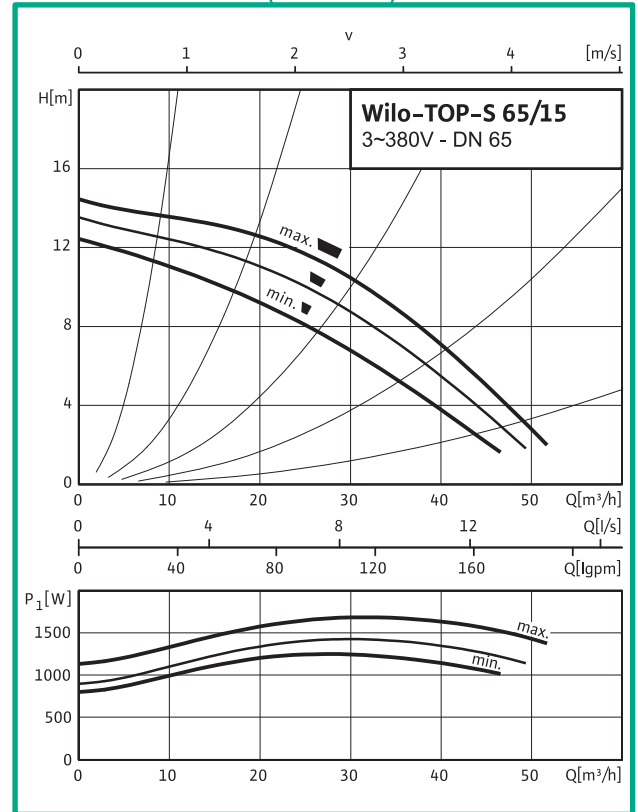



TOP-S IN-LINE 循環泵

TOP-S-60HZ

TOP-S 80/7 EM (1~220V)

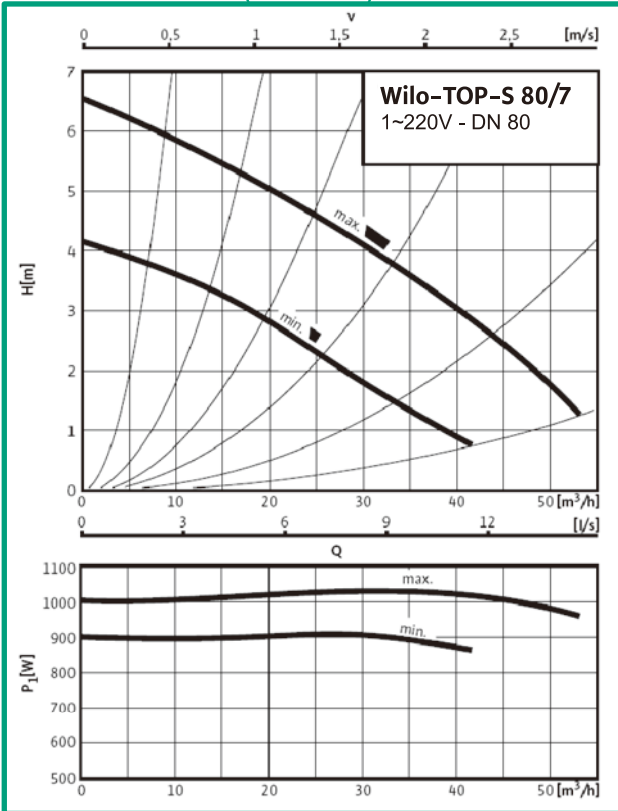

TOP-S 80/7 DM (3~380V)

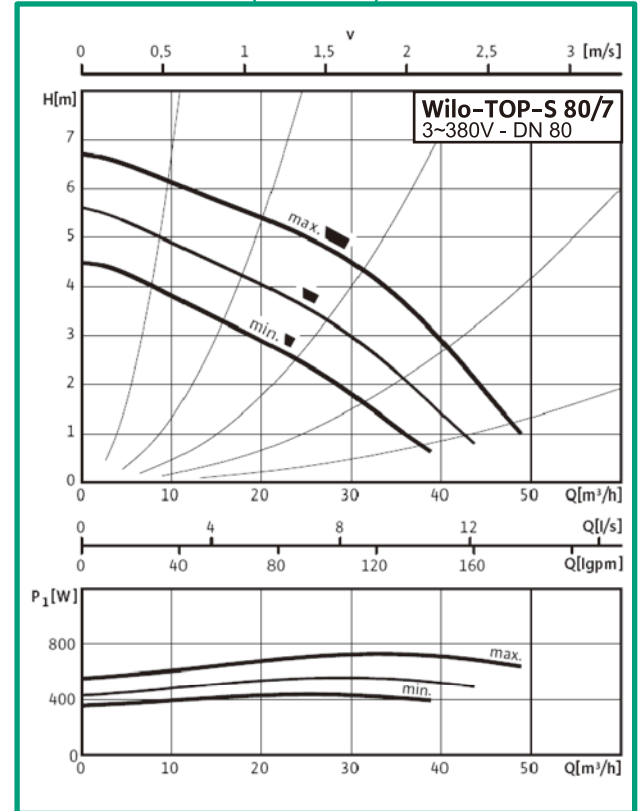

TOP-S 80/10 DM (3~380V)

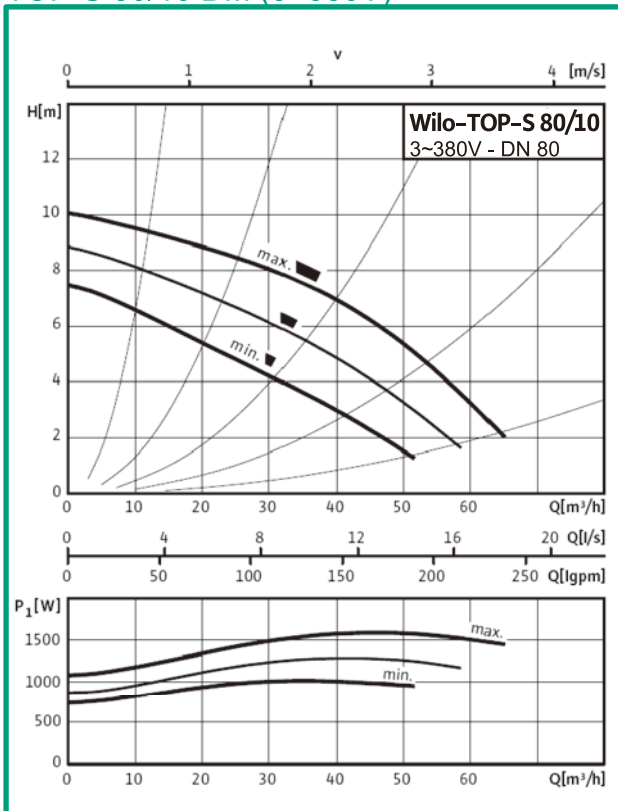

TOP-S 80/15 DM (3~380V)

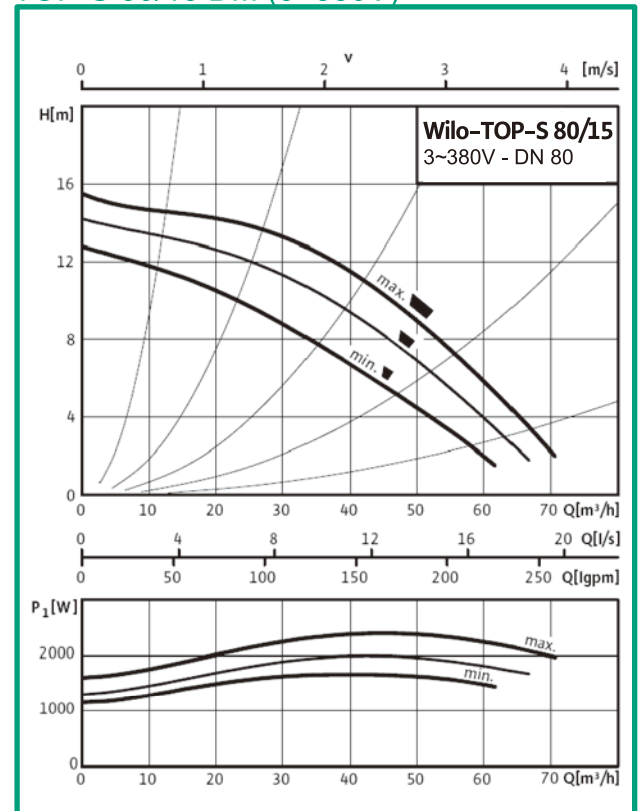



TOP-S IN-LINE 循環泵

TOP-S-60HZ

TOP-S 80/20 DM (3~380V)

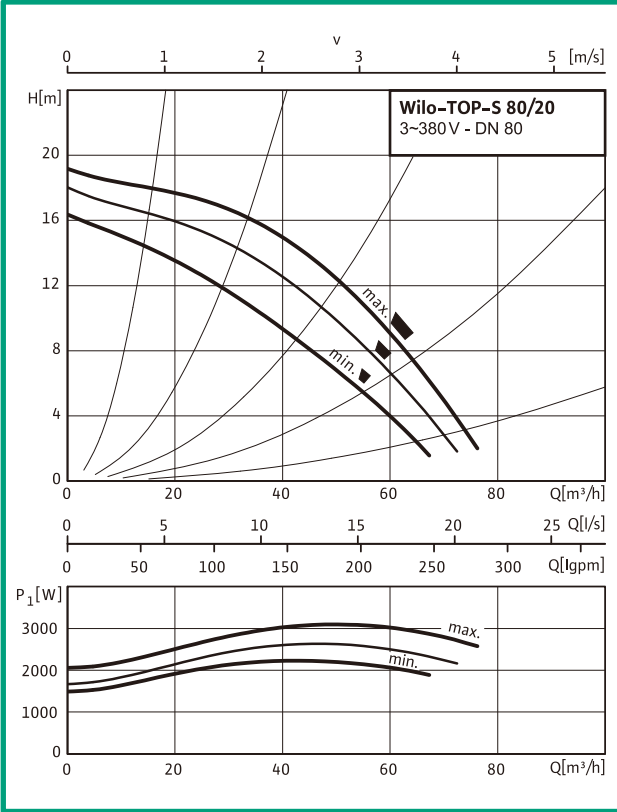

TOP-S 100/10 DM (3~380V)

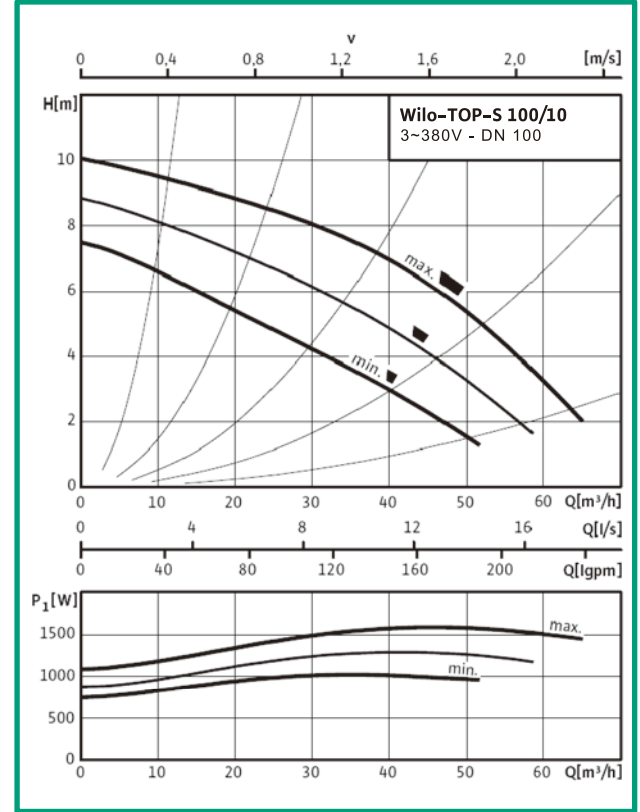



TOP-S IN-LINE 循環泵

TOP-S-60HZ

尺寸圖 A

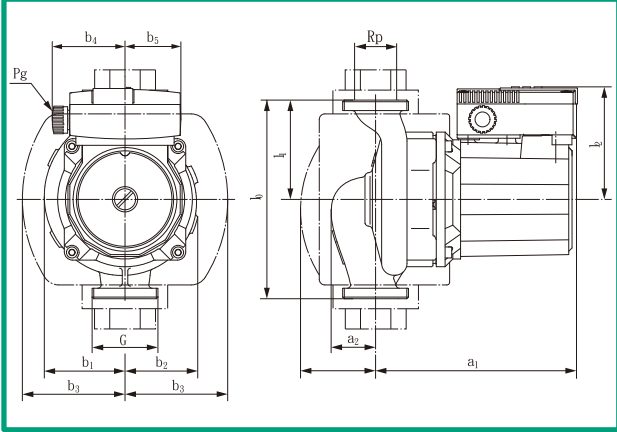

尺寸圖 B

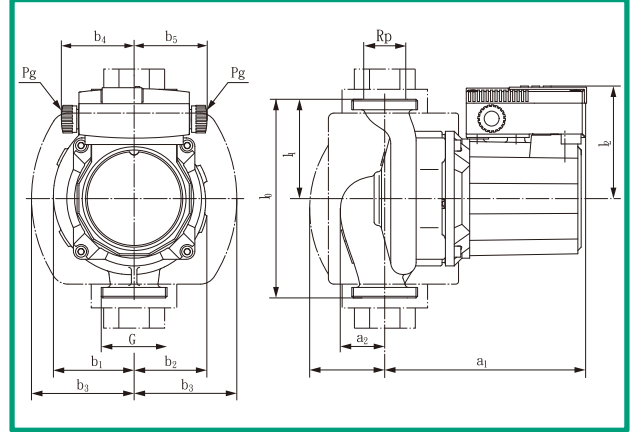

尺寸圖 C

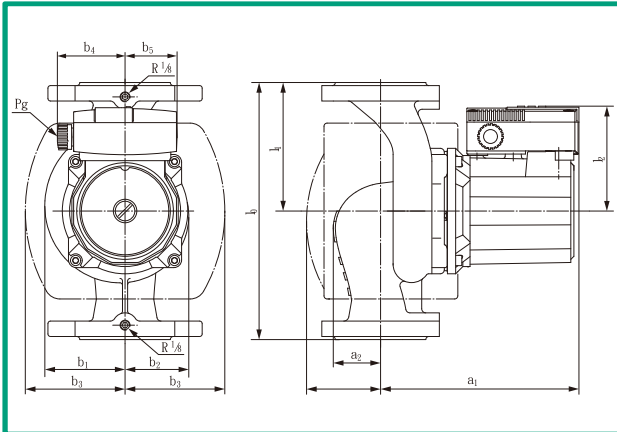

型號	馬力	內徑	外徑	尺寸										重量	尺寸圖
	P1 [W]	Rp	G	l _o	l ₂	a ₁	a ₂	b ₁	b ₂	b ₃	b ₄	b ₅	- [kg]	-	
TOP-S 25/5 EM	140	1"	1 1/2"	180	92	150	40	50	52	88	60	44	5.0	A	
TOP-S 25/5 DM	150	1"	1 1/2"	180	92	150	40	50	52	88	60	44	5.0	A	
TOP-S 25/7 EM	195	1"	1 1/2"	180	92	165	34	66	56	80	60	44	5.0	A	
TOP-S 25/7 DM	200	1"	1 1/2"	180	92	165	34	66	56	80	60	44	5.0	A	
TOP-S 25/10 EM	390	1"	1 1/2"	180	102	172	45	69	68	92	66	66	6.3	B	
TOP-S 25/10 DM	380	1"	1 1/2"	180	102	172	45	69	68	92	66	66	6.3	B	
TOP-S 25/13 EM	260	1"	1 1/2"	180	92	156	30	68	64	89	60	44	5.2	A	
TOP-S 25/13 DM	265	1"	1 1/2"	180	92	156	30	68	64	89	60	44	5.2	A	
TOP-S 30/4 EM	180	1 1/4"	2"	180	92	156	50	53	65	88	60	44	5.0	A	
TOP-S 30/4 DM	160	1 1/4"	2"	180	92	156	50	53	65	88	60	44	5.0	A	
TOP-S 30/5 EM	140	1 1/4"	2"	180	92	150	40	50	52	88	60	44	5.0	A	
TOP-S 30/5 DM	150	1 1/4"	2"	180	92	150	40	50	52	88	60	44	5.0	A	
TOP-S 30/7 EM	195	1 1/4"	2"	180	92	172	34	66	57	88	60	44	5.0	A	
TOP-S 30/7 DM	200	1 1/4"	2"	180	92	172	34	66	57	88	60	44	5.0	A	
TOP-S 30/10 EM	390	1 1/4"	2"	180	92	172	45	69	69	92	66	66	6.3	B	
TOP-S 30/10 DM	380	1 1/4"	2"	180	92	172	45	69	69	92	66	66	6.3	B	
TOP-S 40/4 EM	195	-	-	220	90	178	54	84	60	102	53	44	9.5	C	
TOP-S 40/4 DM	195	-	-	220	90	178	54	84	60	102	53	44	9.5	C	

TOP-S IN-LINE 循環泵

TOP-S-60HZ

尺寸圖 D

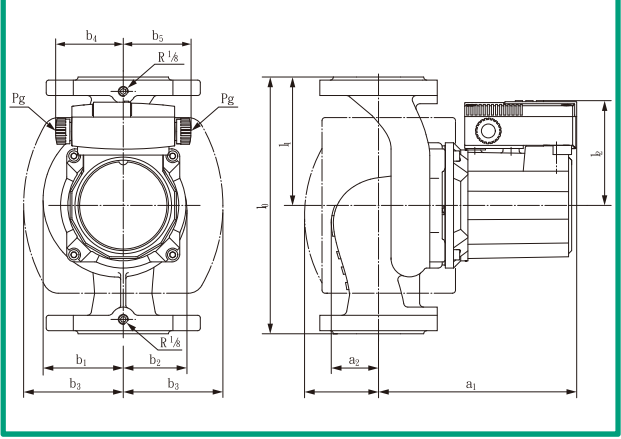

尺寸圖 E

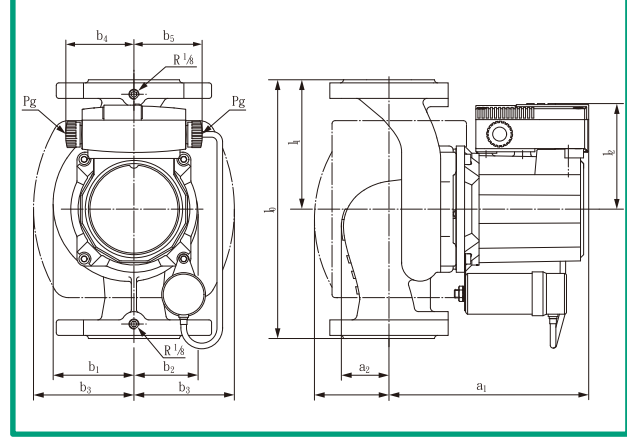

型號	馬力	內徑	外徑	尺寸									重量	尺寸圖
	P1	Rp	G	l ₀	l ₂	a ₁	a ₂	b ₁	b ₂	b ₃	b ₄	b ₅	-	-
	[W]	-	-	[mm]									[kg]	-
TOP-S 40/7 EM	390	-	-	250	102	193	46	78	68	102	66	66	11	D
TOP-S 40/7 DM	370	-	-	250	102	193	46	78	68	102	66	66	11	D
TOP-S 40/10 EM	680	-	-	250	109	216	59	90	80	117	66	66	14.7	D
TOP-S 40/10 DM	585	-	-	250	109	216	59	90	80	117	66	66	14.7	D
TOP-S 40/15 EM	945	-	-	250	119	258	55	99	86	137	66	66	20.8	D
TOP-S 40/15 DM	905	-	-	250	119	258	55	99	86	137	66	66	20.8	D
TOP-S 50/4 EM	330	-	-	240	102	200	53	94	68	117	66	66	13.1	D
TOP-S 50/4 DM	330	-	-	240	102	200	53	94	68	117	66	66	13.1	D
TOP-S 50/7 EM	690	-	-	280	109	224	65	91	77	125	66	66	16.6	D
TOP-S 50/7 DM	610	-	-	280	109	224	65	91	77	125	66	66	16.6	D
TOP-S 50/10 EM	820	-	-	280	109	222	71	101	187	125	66	66	17.8	D
TOP-S 50/10 DM	880	-	-	280	109	222	71	101	187	125	66	66	17.8	D
TOP-S 50/15 DM	1570	-	-	340	119	242	81	105	190	139	66	66	24.9	D
TOP-S 65/7 EM	690	-	-	280	109	226	67	95	79	125	66	66	18.5	D
TOP-S 65/7 DM	590	-	-	280	109	226	67	95	79	125	66	66	18.5	D
TOP-S 65/10 EM	790	-	-	340	109	241	67	110	89	132	66	66	21	D
TOP-S 65/10 DM	845	-	-	340	109	241	67	110	89	132	66	66	21	D
TOP-S 65/13 EM	1450	-	-	340	119	254	67	118	98	142	66	66	27.2	D
TOP-S 65/15 DM	1685	-	-	340	119	254	81	118	98	142	66	66	30.4	D
TOP-S 80/7 EM	800	-	-	360	109	227	81	116	89	140	66	66	23.4	E
TOP-S 80/7 DM	730	-	-	360	109	227	80	116	89	140	66	66	23.4	E
TOP-S 80/10 DM	1590	-	-	360	119	256	80	135	107	162	66	66	30.1	D
TOP-S 80/15 DM	2400	-	-	360	143	316	95	129	108	152	66	66	42.1	D
TOP-S 80/20 DM	3120	-	-	360	143	316	89	129	108	152	66	66	45.5	D
TOP-S 100/10 EM	1590	-	-	280	119	256	96	135	108	162	66	66	33.2	D

TOP-S IN-LINE 循環泵

TOP-S-60HZ

法蘭圖 F

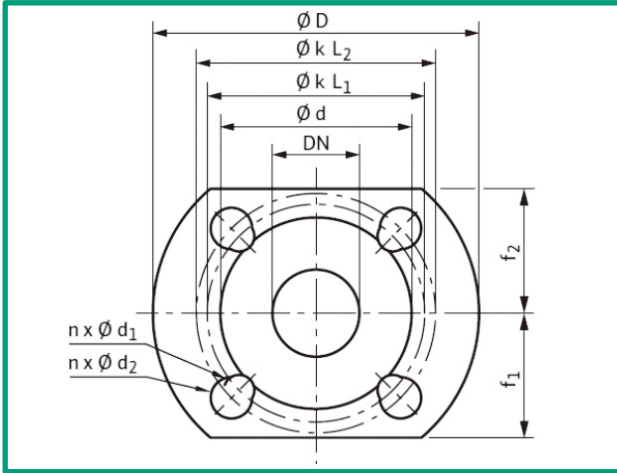

法蘭圖 G

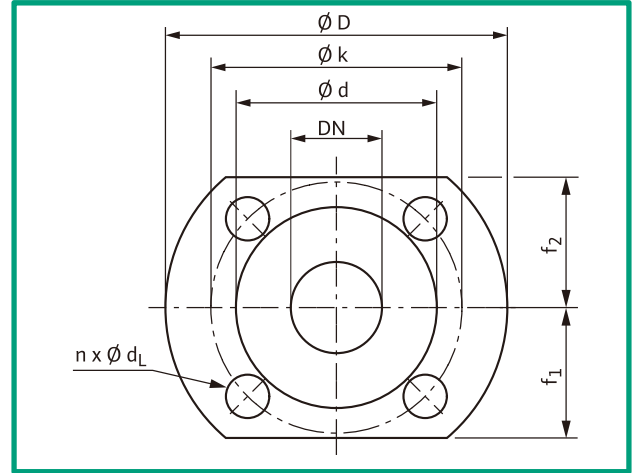

型號	尺寸								尺寸圖
	$\varnothing D$	f_1	f_2	$\varnothing d$	$\varnothing k L_1/k L_2$	$\varnothing K$	$n k \varnothing d L_1/\varnothing d L_2$	$n \times \varnothing d L$	-
	[mm]								-
TOP-S 40/4	150	65	65	84	100/110	-	4x14/19	-	F
TOP-S 40/7	150	65	65	84	100/110	-	4x14/19	-	F
TOP-S 40/10	150	65	65	84	100/110	-	4x14/19	-	F
TOP-S 40/15	150	65	65	84	100/110	-	4x14/19	-	F
TOP-S 50/4	165	70	70	99	110/125	-	4x14/19	-	F
TOP-S 50/7	165	70	70	99	110/125	-	4x14/19	-	F
TOP-S 50/10	165	70	75	99	110/125	-	4x14/19	-	F
TOP-S 50/15	165	75	83	99	110/125	-	4x14/19	-	F
TOP-S 65/7	185	80	80	118	130/145	-	4x14/19	-	F
TOP-S 65/10	185	80	80	118	130/145	-	4x14/19	-	F
TOP-S 65/13	185	80	80	118	130/145	-	4x14/19	-	F
TOP-S 65/15	185	80	80	118	130/145	-	4x14/19	-	F
TOP-S 80/7	200	90	90	132	-	150	-	4x19	G
TOP-S 80/7	200	90	90	132	-	160	-	8x19	G
TOP-S 80/10	200	90	90	132	-	150	-	4x19	G
TOP-S 80/10	200	90	90	132	-	160	-	8x19	G
TOP-S 80/15	200	90	90	132	-	150	-	4x19	G
TOP-S 80/15	200	90	90	132	-	160	-	8x19	G
TOP-S 80/20	200	90	90	132	-	170	-	4x19	G
TOP-S 80/20	200	90	90	132	-	160	-	8x19	G
TOP-S 100/10	220	100	100	156	-	170	-	4x19	G
TOP-S 100/10	220	100	100	156	-	180	-	8x19	G